

## **“Honest Parts Made From Genuine Materials”**

Contact sales@pacmetaerospace or call 909-218-8889 for inquiries!

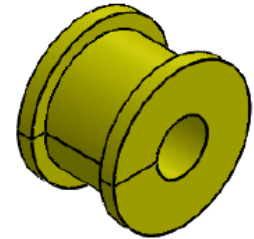
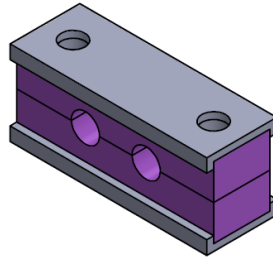
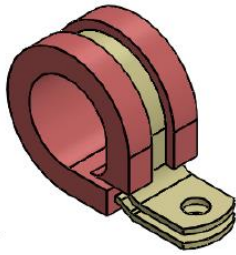

### **Cushioned Clamps**

### **Fairlead Blocks**

### **Grommets**



**PM100 Series  
Loop Clamps**

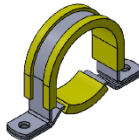

**PM200 Series  
Saddle Clamps**

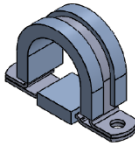

**PM300 Series  
Double Mount Clamps**

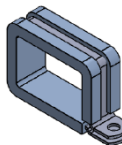

**PM400 Series  
Rectangular Clamps**

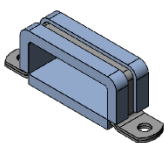

**PM500 Series  
Double Mount Rectangular**

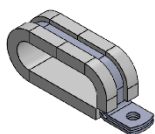

**PM600 Series  
Multiple Tube Clamps**

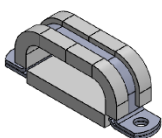

**PM700 Series  
Multiple Tube, Double Mount**



**PM800 Series  
Center Mount Clamps**

---

*Pacmet Aerospace specializes in the testing, design, and manufacturing of cushioned clamps, fairlead blocks, and grommets as well as many other vibration dampening assemblies utilizing elastomers.*

---

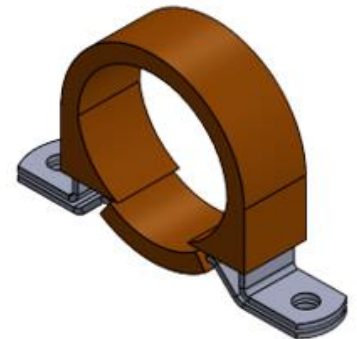
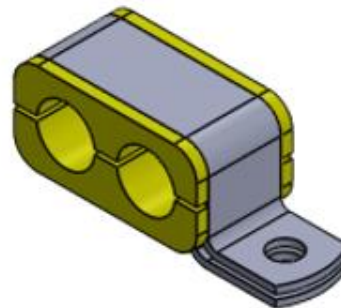
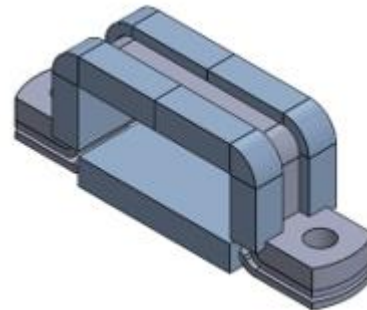

For applications not covered by our standard clamp offerings or customers looking for a more specialized product, contact Pacmet Aerospace for design assistance. Our team of experienced engineers will assist you in the design of the perfect clamping system for your application.